

PROCESSING INSTRUCTIONS CABLE ROUTING UND GLAZING REBATE VENTILATION

GLAZING REBATE VENTILATION

Activate the glazing rebate ventilation by just drilling a hole each at the top and bottom of the hinge and lock sides, reaching to the core (see drilling pattern [section A - A]). This borehole must end before the sealing plane and thus in the external climate. The steel frame has pre-drilled boreholes at the relevant position, so that it needs not be drilled again.

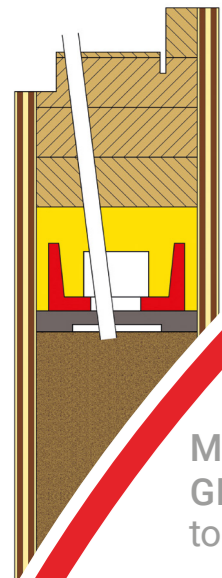

MILLING THE GROOVE top

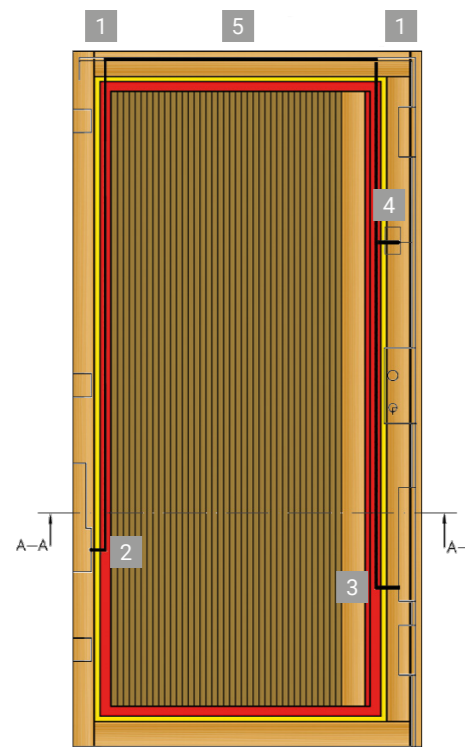
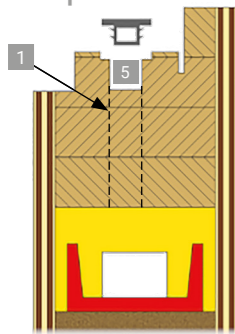

CABLE ROUTING

The cable duct is reached by drilling a borehole each 1 into the blank surface on the hinge and lock sides. An additional access borehole 2 to the cable duct must be drilled on the hinge side, and to the A-opener/motor on the lock side. 3 Connect the two existing cable ducts through a milled groove 5 on the door leaf surface (see details "milling the groove at top"). Guide cable through this groove from the hinge side to the lock side. After introducing the cable, reversibly close the groove again (e.g. faceplate gasket). For orders with CNC-machining, a connecting espagnolette groove (16 mm) is milled in at the faceplate level.

ACCESS CONTROL SYSTEM

Access control systems (e.g. fingerprint) should be installed outside of the steel frame and are connected to the lock-side cable duct by a borehole. 4 If positioning outside of the steel frame is not possible, please give relevant information when placing the order. In this case an additional conduit is introduced from the cable duct to the relevant installation position.

DRILLING PATTERN (SECTION A - A)

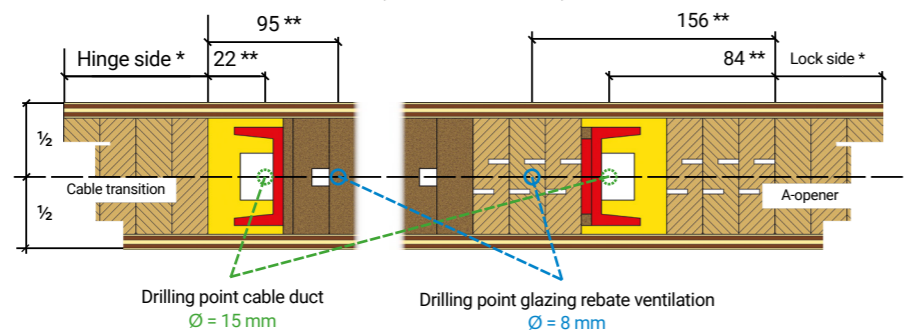

* visible Wood
** from end grain edge to centre of access borehole



PROCESSING INSTRUCTIONS FOR EXTERNAL DOOR BLANKS

Moisten blanks with water before processing and subject both sides to a visual and dimensional inspection after approx. 60 minutes. Do not process damaged or defective blanks.

A. Storage/conditioning

1. Store external door blanks in such a way that the expected moisture content (12% +/- 1%) of the blank is maintained also during intermediate storage. Store blanks flat on three well aligned timber supports to avoid distortions or other irregularities.
2. Protect blanks from ground water and wall moisture.

B. Shortening of blanks

1. Before shortening the blanks and cutting of apertures for glazed panels check position of steel frame (see technical data sheet with drawing).
2. Reduction in length is always dependent on the applicable rebate geometry and hardware used. Observe sufficient timber width for proper screw fastening.
3. The steel frame must be surrounded by 10 mm unmachined solid wood. On the lock side, the blank should be shortened only by the lipping dimensions to maintain the lock case depth.
4. The insert lipping dimensions are specified in the attached data sheet (ATTENTION: measure hinge side for checking type of blank). The stamp with the technical data is at the BOTTOM!

C. Attaching the lippings

1. Check moisture content (12% +/- 1%) of lipping before glue application. If possible, store lipping and blank in an air-conditioned room for one week.
2. For attachment use glue of stress group D4 (EN 204). Heat resistance of at least 50°C must be guaranteed during the 30 minute pressing time.
3. Lippings should be made of solid wood with vertical growth rings (low wood shrinkage).
4. Avoid thickness tolerances between door blank and solid wood lipping (glue failure).

D. Blank veneering

Before veneering calibrate blank and remove dust from blank!

1. Moisture content of the veneer must be approx. 12% +/- 1%.
2. External door blanks with diagonal cross veneer must always be veneered.
3. Different veneer thicknesses and sliced veneers cause glue failures and must not be glued. Avoid using hot melt threads because low pressing temperature may cause glue failure.
4. The adhesive bond must be waterproof and heat resistant up to 100°C (D4 glue).
5. The structure must be symmetrical (identical internal and external veneer thicknesses).

E. Pressing pressure

1. As a rule, the pressing temperature and pressing time depend on the types of glue and hardener used. Important: always observe manufacturer instructions! The pressing temperature must not exceed 100°C for a maximum duration of 10 minutes.
2. After pressing store doors with the two faces uniformly covered, between 1 and 2 days for intermediate conditioning.
3. The core of landing doors and acoustic/heat resistant doors cannot be veneered due to the core layer structure!

F. Apertures for glazed panels and surface treatment

Before surface treatment, moisten top layer with water, grind and remove dust!

1. Doors with apertures for glazed panels or infill panels featuring surface-mounted or rebated glazing beads or infill panel fixings, must be so designed that no moisture penetrates into the door leaf.
2. The engagement length of the screws used for infill panel fixings or glazing beads must be at least 40 mm for the core.
3. The infill panel fixings and glazing beads must be pre-drilled with a hole diameter 0.5 mm larger than the screw diameter.
4. Before, the borehole surface must be reworked using a countersink. It is not possible to countersink the screws when screwing them in!
5. Infill panel fixings and glazing beads can always be glued!
6. The mitred corners of the infill panel fixings and glazing beads must always be sealed.
7. Make sure that the doors are not exposed to moisture (shell construction moisture), because the colour and structure of the interior steel frame (extreme load) may show.
8. Untreated, primed, and oiled doors are excluded from warranty.
9. Moisten surface with water before priming and sand after drying.
10. Apply finishes as specified by the paint manufacturer. Special care must be taken that the top and bottom areas of the front sides are coated with a minimum dry layer thickness of 100 µm for woodstains and 120 µm for opaque finishes. In particular in external areas, the edges should be rounded with a 2 mm radius to prevent separation of the applied finish!
11. The surface structure must always be symmetrical (external to internal face).

All the information and instructions given here are based on experience or test results. They, however, must be adapted to the local conditions and materials used. For special dimensions exceeding the maximum standard dimensions (113 x 224 cm), no test certificates are available, so that the tolerances specified in the test certificate do not apply in this respect and exceedances may occur. All this is herewith agreed by the customer/client as being in accordance with the contract. In case of complaints, only the blank will be replaced.

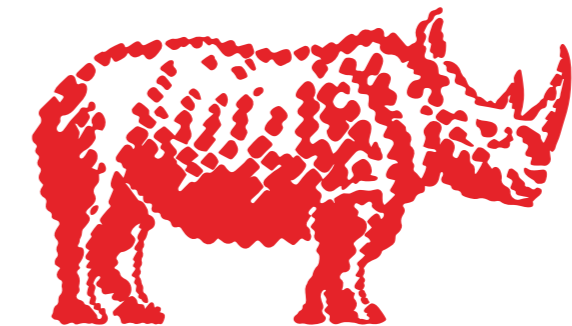

Haustüren-Ring
STRONG BY REINFORCEMENT

Haustüren-Ring GmbH
Beckerstraße 2a
85049 Ingolstadt
www.haustueren-ring.de
+49 (0) 841 95 49 95
info@haustueren-ring.de

TYPE ÖKO PASSIV
ÖKO PASSIV VARIABEL
73 - 108 mm

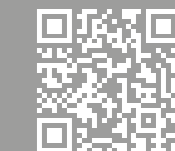

TYPE ÖKO PASSIV VARIABEL

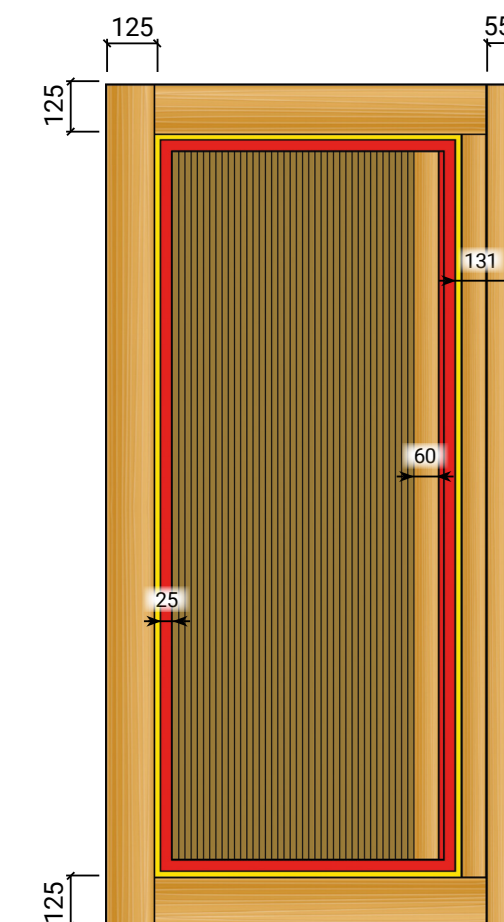

minimum stile widths, for NON-shortened blanks in mm

Bottom	Top	Hinge side	Lock side
175	175	175	175

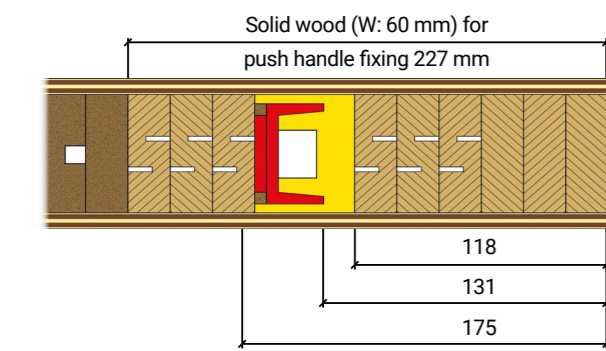
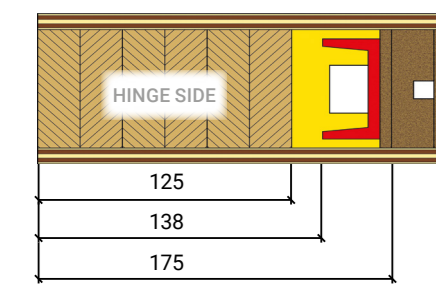

TECHNICAL DATA Blanks Type Öko Passiv

Sound insulation values of unit:	Standard core $R_{wp} = 32$ dB Acoustic core ¹ $R_{wp} = 43$ dB
U-value unit without aperture for glazed panel:	Standard core 78 mm 1,0 W/m ² K 88 mm 0,9 W/m ² K 98 mm 0,8 W/m ² K Acoustic core ¹ 78 mm 1,15 W/m ² K 88 mm 0,91 W/m ² K
Test method DIN EN 1121:	Test climates c, d, e
Classification DIN EN 12219:	Class 3 (c, d, e)
Burglar resistance DIN EN 1627:	RC2, RC2N
Ability to release:	Yes, with licence system
Fire safety:	Yes, with licence system

¹ Acoustic cores are not generally included. They must be specified when placing the order.



FIRST STEPS

BEFORE PROCESSING ...

... of blank, check hinge-side insert lipping width for exact type determination!

Moisten blanks with water before processing and subject both sides of blanks to visual and dimensional inspection after approx. 60 minutes. Do not process damaged or defective blanks.

The dimensions given in the scheme show the insert lipping width in mm up to the beginning of the steel frame. When shortening the blanks, take account of their rebate dimensions. A 10 mm distance to the steel frame without any milled groove or rebate should be maintained, so that the insert remains well edged (shear and tensile resistance of adhesive bond).

The bottom is marked with the technical data of the blank.

Shortening of the lock side is not allowed!

ATTENTION: For apertures for glazed panels take account of the allowance for fixing the glazing beads!

TYPE ÖKO PASSIV VARIABEL

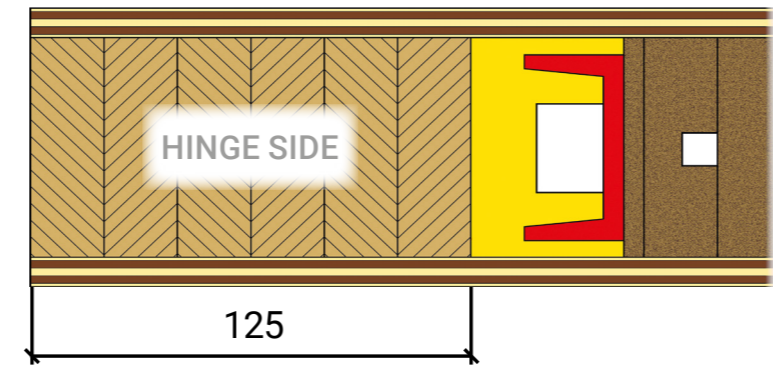

TYPE ÖKO PASSIV

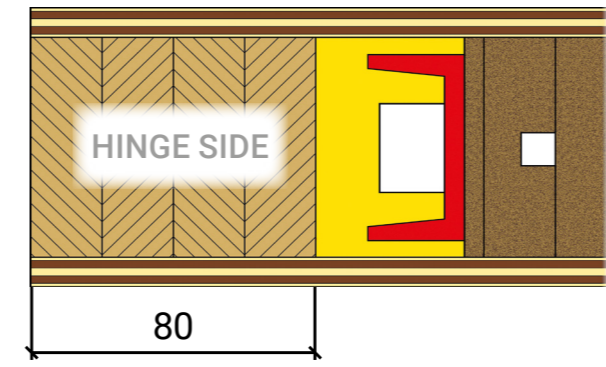

TYPE ÖKO PASSIV

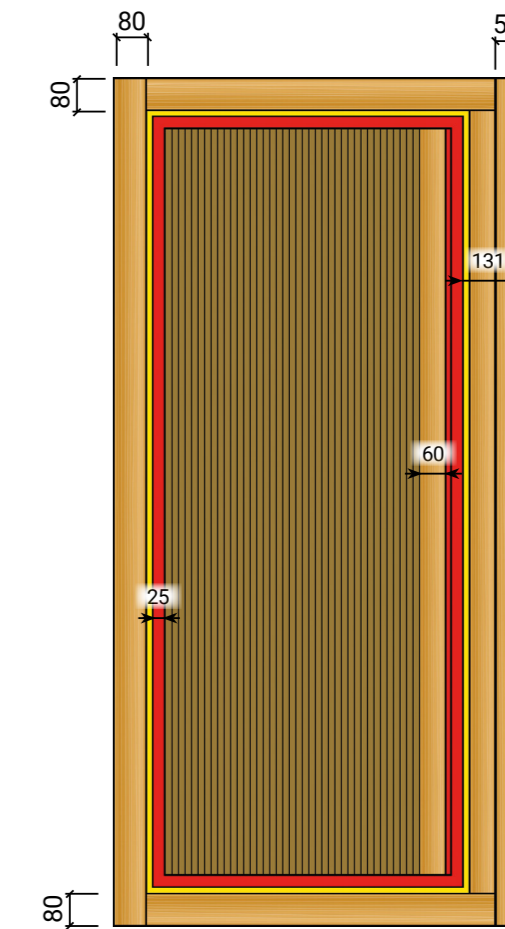

minimum stile widths, for NON-shortened blanks in mm

Bottom	Top	Hinge side	Lock side
130	130	130	175

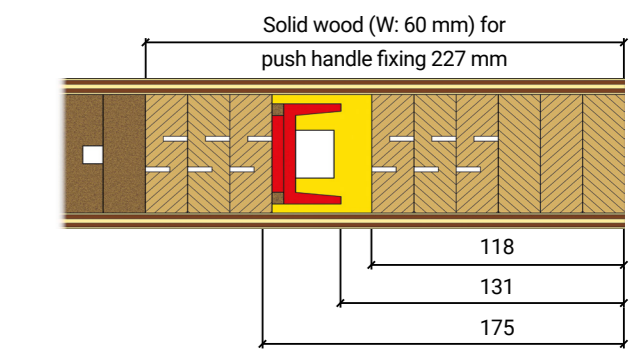
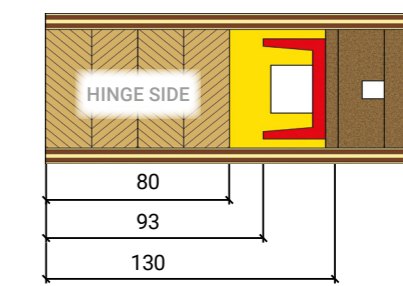

Veneer Options

L = vertical veneer; Q = horizontal veneer;
F = fineline; E = insert lipping; M = sliced veneer

OAK	M L Q E
OAK knotty	M L Q
SPRUCE	M L Q F E
PINE	M L F E
LARCH	M L Q F E
LARCH knotty	M L Q
SAPOLI MAHOGANY	M L
MERANTI	L F E
MDF	

Veneer thickness 0.8 - 0.6 mm for goods on stock

For further embossed top layers such as Oak Rustikal and other timber species visit our website!